



100% Trucknology®.

MAN TGL and TGM.



Reliability and innovation. Together: 100% Trucknology®.

We developed the TGL and TGM vehicles from the MAN Trucknology® generation according to a typical MAN principle: maximum customer benefit. The result: vehicles with maximum useful value. Trucks that combine excellent economy with outstanding transport performance, built to the highest standards of comfort and convenience, reliability, safety and environmental acceptability.

The TGL, in the innovative Trucknology® class from 7.49 to 12 tonnes, stands for professional standards and pure productivity. As soon as it appeared, it was voted "Truck of the Year 2006" for its unique comfort and convenience, its outstanding performance and handling on the road and its economical powertrain.

The TGM is the new force in the medium-weight category from 13 to 26 tonnes, and it's in a class by itself, unsurpassed in payload, ride quality and dynamism. More powerful engines, new variants, enhanced efficiency – all these are advantages that will boost your turnover.

Together with the big range of mobility services offered to you by MAN Service, MAN Support and MAN Finance, the TGL and TGM open up a new dimension in economical truck operation. Full-service transport back-up benefits owner-drivers as well as fleet operators and international logistics providers. For all of them, the Trucknology® generation is the key to success.



Some of the equipment illustrated or described in this brochure is not a standard feature.

Entry to the Trucknology® class: MAN TGL.

The 7.5-tonne TGL is the lightweight model in this series – but it's all truck, from cab to axles. Its low tare weight means that higher payloads are possible, and its vivid performance and excellent manoeuvrability are equally welcome features. Equipped with the

spacious C cab, it's the champion in classic freight distribution. With the L or LX cab in the 8-tonne segment, it demonstrates its fine qualities on longer tours as well. Its motto: design follows function!





With this truck, so much is possible: MAN TGM.

Can a truck be designed for high payload and large load volume at one and the same time? The TGM as a 15-tonner proves that this compromise works brilliantly. It's a truck of all trades, with scarcely any limits in local distribution or long-haul transport. The TGL's gross train weight can be up to 24 tonnes, the 15-tonne TGM's up to 30 tonnes.

Another highlight available as an option is full air suspension.

Together with MAN Tronic, ECAS (Electronically Controlled Air Suspension) maintains the highest levels of ride comfort and protects the load against rough treatment. The 15-tonner can be run at the reduced 11.99-tonne load limit, and is then for instance not liable for German road tolls. Fitted with 19.5-inch tyres it has no difficulty in demonstrating its supremely economical performance.

Higher payloads, higher efficiency too.

A truck that weighs less carries more. This was the principle that led to the 18-tonne model in the TGM series. With its exceptionally low unladen weight, it's the payload champion in its class – a weighty argument indeed! Particularly since higher payload usually means higher turnover. Equipped with the supremely spacious LX cab, and with full air suspension available as an option, this 18-tonner with its long-distance capability represents tempting value for money.

A notable feature: the economical powertrain with its 12-speed MAN TipMatic transmission fed with massive power from the 240 kW (326 hp) 6-cylinder engine with two-stage turbocharging. The perfect synthesis of power, performance and transport quality.

Power that gets things moving.

Give it a truly challenging task, and it rises to the occasion: the TGM 18-tonner tackles the day's work calmly and supremely, whatever needs to be done. And when the going is particularly tough, the 4x4 is ideal for the job.

The 13-tonner with all-wheel drive and rear-axle air suspension combines high payload with optimal traction and road safety. Perhaps a size larger? In that case the 6x4 version of the 26-tonner is an ideal choice. As a solo vehicle with rear-end tipping body or truck mixer it leads its class for maximum payload.

Reliability meets elegance and dynamism.

Small but just great – that's the compact, agile 8-tonner, a totally reliable partner however tough the task may be. With a sturdy tipper body, it thrives on hard work. It's an athlete with concentrated muscle-power, but also a stylist that moves elegantly and dynamically. Light weight, manoeuvrability, strength – these are qualities to build a business on – in the construction industry, in the craft trades and in small companies. The external data exchange interface (KSM) and the opportunities it offers make this vehicle more functional still.



"I offered to pay him more than the going rate. He joined the company – but only because he was so impressed by his new place of work."



Motivation is an art, maybe – but we can offer you several ways of greatly increasing your prospects of success. The C, L and LX cabs and the crew cab take the needs of the driver and accompanying personnel systematically into account. In each of these cabs, practical and ergonomically effective features can be seen in every detail as well as in the overall concept. It's hardly surprising when truckers fall in love with their job all over again.



Brilliant use of space in four sizes. The cabs for the TGL and TGM.

Comfort, convenience and safety.

Whichever Trucknology® cab you choose, you'll enjoy optimal comfort, ergonomics – and safety. All these cabs comply with the most demanding crash safety standards and are in accordance with the ECE-R29 directive. A safety cell combined with special controlled-deformation elements ensures the highest possible level of occupant protection.

As an option, a steel bumper closely matching the normal synthetic part is available for all cab versions.

MAN received the iF Design Award for its Trucknology® Generation, a highly regarded accolade for outstanding industrial design.



L design



LX design



Crew cab

C design.

With its compact dimensions, the C design is the first choice for daily delivery work. Particularly convenient features are the extremely low entry height, the wide door-opening angle and the ease with which the cab can be crossed to the passenger's side. Cab dimensions: 1,622 mm long, 2,240 mm wide, two-man passenger seat optional.

L design.

Convincing in its comfort, convenience and access height, the L cab has a large bunk bed and plenty of storage space to make it ideal for medium-length journeys.

Cab dimensions: 2,280 mm long, 2,240 mm wide, full-size bunk bed.

LX design.

With its effective blend of comfort and functionality, the high-roof LX cab sets the standards for long-distance work. It is trimmed and equipped to a high standard, has a large bunk bed and is conveniently accessible.

Cab dimensions: 2,280 mm long, 2,240 mm wide; option of upper bunk.

Crew cab.

The four-door crew cab means first-class travel in the second row as well. With the four-person rear bench seat occupied, seven people (6 + driver) can be carried.

Cab dimensions: 2,785 mm long, 2,376 mm wide, with many large, practical storage spaces and compartments.



A small step for the driver.

If you can't even remember how often you board and leave the truck every day, then you'll value convenient access to the cab very highly. The C cab, with its extremely low access height, makes the driver's work so much easier, and he or she can move across to the pavement side just as conveniently. The L and LX cabs with two steps still have a very moderate access height. The doors open wide, to an angle of almost 90 degrees, and the door and grab handles are ergonomically located to make boarding and leaving all these cabs a much easier task.

You never thought we'd sink so low just to make you comfortable.



Air-sprung driver's comfort seat with integrated belt system and optional armrests.

Listen to what your back tells you.

How good the seats in the TGL or TGM really are? Part of your body knows the answer: your back. There is in fact a choice of seats, but all of them take the latest industrial medicine research into account. The standard seat is static, with position adjustment; the comfort seat has air suspension; the luxury seat also features a lumbar support and is heated. And that's not all: the innovative climate-controlled seat has heating and a fan that directs a temperature-controlled airflow through the seat cushion and seat back to conjure up a most agreeable feeling of unsurpassed comfort. In hot weather this almost undetectable current of unheated air is most refreshing.

A pleasant climate on board.

In winter, highly efficient heating systems keep the occupants warm and prevent the windows of the TGL and TGM from misting up. The optional air-conditioning with automatic temperature control keeps conditions inside the cab close to ideal, but for truly extreme climates a diesel-fuelled auxiliary heater with thermostat can be specified.

Double passenger seat (optional extra).



Convenient cross-cab access on trucks with a four-cylinder engine.



Second row of seats in crew cab, with storage space under the fold-up seats.



Crew cab with four doors opening to a wide angle.



If you can see it,
we put it in the right place.



Pressing a footwell knob allows the steering wheel to be adjusted steplessly in height and angle.



Multifunction steering wheel with controls for MAN radio and cruise control etc.

A cockpit with ergonomics and style.

It's easy to sum up the virtues of this well laid-out, ergonomically planned cockpit: everything's where it should be. The glare-free instruments provide instant information, the controls logically arranged and easy to reach. With the optional multifunction steering wheel you have rapid access to even more functions and can obtain information, receive telephone calls or adjust the radio settings without taking your hands off the wheel. If a knob in the footwell is pressed, the steering wheel can be adjusted steplessly

for height and angle – and to make boarding and leaving even easier it can be released and swung up in a single easy movement. To keep in touch with events during the journey there's a modern driver information management system with two instrument clusters. You can choose between "Baseline L" for the solo truck and the exceptionally stylish "Baseline" version for use when towing a trailer; it comes with additional functions and chrome-plated dial bezels.

**You want to take all that with you?
No problem.**



Coat? Hat? Kitchen sink? Well almost ...

Tidiness in the cab is a most desirable thing, and so we've provided large storage compartments above the windscreen and bins and pockets in both doors. A very useful feature for delivery work is the ingenious storage box with integral but detachable desktop; it's available as an optional extra.

In the centre of the dashboard are cup holders and several compartments for small objects. Larger ones can be stored effectively in the centre-tunnel console

and the storage compartment on the rear wall of the cab. For your personal property the L and LX cabs have a large, illuminated luggage compartment that's accessible from both inside and outside the vehicle. Another storage space accessible from outside houses the tools and other items of equipment. And the LX cab also has a spacious, modular-element storage system above the windscreen for a total storage volume of up to 540 litres.



Storage compartment in C cab.



Luggage compartment in L and LX cabs.



Storage box with removable desktop in the crew cab.



Storage system in crew cab.



Stowage space under the second row of seats in the crew cab.



Storage compartment above windscreen and roof skylight in C cab.



Storage compartment above windscreen and electric sliding/tilt sunroof in LX cab.



A good day starts after a good night.

The comfortable bunk beds in L and LX cabs (a second, upper bunk can be installed in the LX cab as an optional extra) can present a problem: getting up in the morning! With a grid base for the 7-zone cold-foam mattress, the standard of comfort is something that others can only dream of. These bunks were developed with assistance from the Ergonomie-Institut-München GmbH and have been awarded the quality certificate "Ergonomic reclining comfort" by the Bavarian Regional Trade Office (LGA). The washable, highly elastic fabric used to cover the mattress is made from free-breathing material and is extremely hygienic. Another impressive feature of these bunks is their generous surface area. All this goes to show that MAN looks after you in your waking and sleeping hours.



Comfort in every detail.

In the high-roof LX cab we've thought of everything. Standing height, freedom of movement and cab suspension quality are in a class all their own. There are two additional closed, illuminated storage compartments over the windscreen with plenty of space for travel bags and clothing. But it's often the smaller details that add enormously to comfort, for example the MAN sound system or the red-and-white interior lights that provide pleasant lighting where it's needed and can be dimmed. Another ingenious optional extra is the insulated storage box, also available with cooling – an ideal way of making a long-distance tour more pleasant.

Insulated box, with cooling if required.



Convenience module with alarm clock.

"Good night"
has such a welcoming sound.



Typical MAN. The best features are under the bonnet.

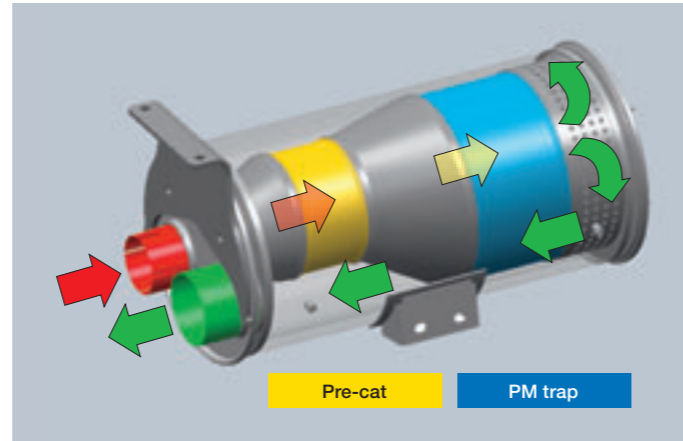
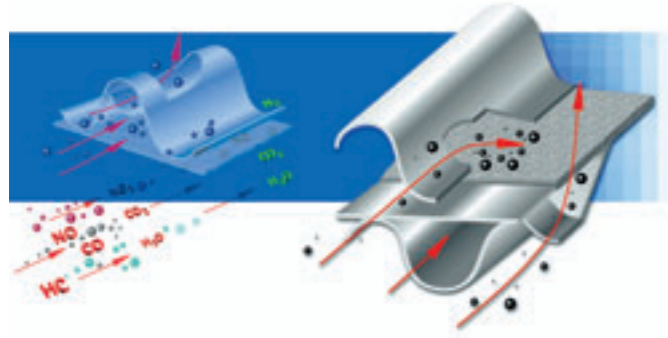

Exhaust-gas ducting, TGL/TGM silencer.

Power from four or six cylinders.

These trucks have modern Euro 4 common-rail engines that are the torque champions in their respective power categories – something you'll notice every time you drive off and accelerate, on every hill, in fact throughout even the longest journey. Whichever engine you choose, a well-shaped torque curve makes it easier to drive economically, with a minimum of gear changes. The TGL series is powered by 4-cylinder units with plenty of pulling power, including a 151 kW (206 hp) engine with two-stage turbocharging for supreme strength in every engine-speed range. The sturdy 6-cylinder, 176 kW (240 hp) engine is available for either the TGL or the TGM, and two further 6-cylinder units, rated at 206 kW (280 hp), and (with two-stage turbocharging) at 240 kW (326 hp) round off this "power programme" for the TGM series.

MAN's brilliant solution to Euro 4.

All engines for the TGL and TGM series are equipped with the MAN PM-KAT® filter combined with exhaust gas recirculation (EGR) and comply with the Euro 4 emission limits. This technology needs no additives, weighs less than other systems and achieves a proportionately greater reduction in ultra-fine particulates – yet it needs no routine maintenance. MAN's PM-KAT® technology has been awarded the coveted

BDI Environment Prize from the German Industry Federation in the "Environmentally Compatible Products" category. The basic EGR technology is economical and suitable for use when Euro 5 and later limits come into force.

Automatically in the green range.

Economical driving calls for a trained hand on the gear lever. The easiest and most convenient way to change gear is with the MAN TipMatic, which can be operated either manually using a touch-action lever or fully automatically. If the exhaust brake takes effect, this automated gearbox selects the most suitable gear for maximum engine braking – an obvious safety bonus. But MAN TipMatic is also exceptionally economical: it minimises fuel consumption and avoids overloading the driveline. It's available with six speeds for 4-cylinder engines and as a 12-speed version for 6-cylinder engines.

For those who prefer to select their own gears, easy-action gearboxes with five, six or nine speeds are available; the 9-speed versions are always specified for TGM-series vehicles. All of these gearboxes show the currently selected gear in the driver's display.



High-torque 4-cylinder diesel with two-stage turbocharging, 151 kW (206 hp).

Framed in the best sense of the word.

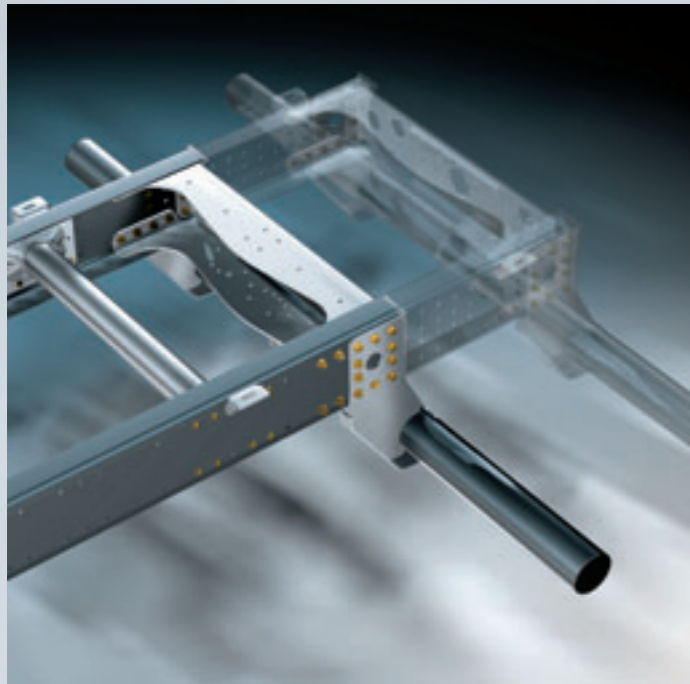

Variable rear end of frame.

Maximum strength, minimum weight.

The chassis frames for TGL and TGM vehicles are designed and rated for maximum strength and load capacity, but they are none the less extremely light. After all, every scrap of unnecessary weight eats away at the payload and costs money. This well-planned frame concept with its flat upper surface means that bodies and equipment can be easily and quickly attached – without drilling additional holes that could affect the corrosion-proofing. And thanks to MAN Tronic, the well-proven electronic structure based on CAN bus technology, and the external data exchange interface (KSM) the way is clear for an extensive range of vehicle and body functions.

A perfect fit anytime.

So that TGL and TGM chassis can be matched to any body length, we came up with a neat idea: a frame with a variable rear end. Close hole spacing is provided so that the frame overhang can be matched to the body without any additional drilling. One neat cut and the job's done. The end cross-member is bolted into place so that repositioning it presents no problems.



Power on all fours: the TGM 4x4.

With the TGM 4x4, you can make up a lot of ground when the going is tough and optimal traction is called for. On the construction site, for communal road works or winter services or for off-road journeys it has driver-engaged all-wheel drive as a standard feature or, as an optional extra, permanent all-wheel drive with a pneumatically engaged inter-axle differential lock.

A new top-class feature of MAN's all-wheel-drive technology is the optional electronic transfer case and lock management system. It supports the driver on the road and off, helping him to operate the vehicle according to the traction required. It also protects the driveline.

The benefits are a lot more mobility and safety when driving away from the beaten track or when the surface is poor and traction problems would otherwise occur. Also fitted to all-wheel-drive vehicles: planetary-hub axles for greater ground clearance, drum brakes and anti-roll bars. Three different cab concepts can be fitted to the TGM 4x4, and another optional extra is the sturdy steel bumper for tough operating conditions.

4x4 chassis are available as 13-tonners with combined leaf and air suspension – a combination unique in this class – and as 18-tonners with all-steel suspension; either single or twin tyres can be selected for both. A special low-height version of the TGM 4x4 13-tonner is also available for firefighting vehicles.

Strong steel bumper with the same appearance as the standard synthetic bumper.



Rear-axle air suspension.

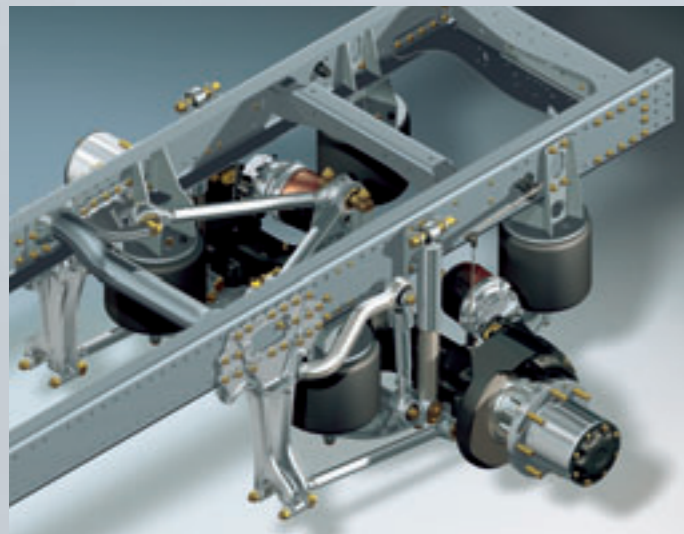

Support you can trust: running gear designed for comfort and dynamism.

All power to the axles.

A high-performance driveline needs efficient driven axles. On the TGL and TGM these are the latest version of the hypoid bevel axles for road vehicles, notable for their low weight, high load capacity, wide performance range and extended oil-change intervals. Hypoid bevel rear axles cause very little noise or friction. They're as kind to your ears as they are to your wallet. A big

choice of axle ratios enables you to configure the driveline for maximum power transmission at all engine speeds. And as an option these hypoid-bevel axles can be equipped with pneumatically actuated differential locks for reliable drive-off and traction on low-grip surfaces such as ice, slush or snow.



Built for strength: TGM 6x4 26-tonner.

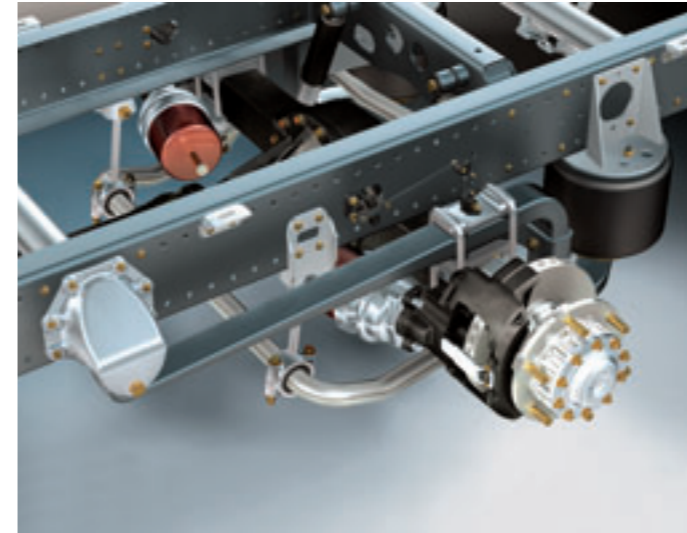

2-bellows rear-axle air suspension for the TGL.

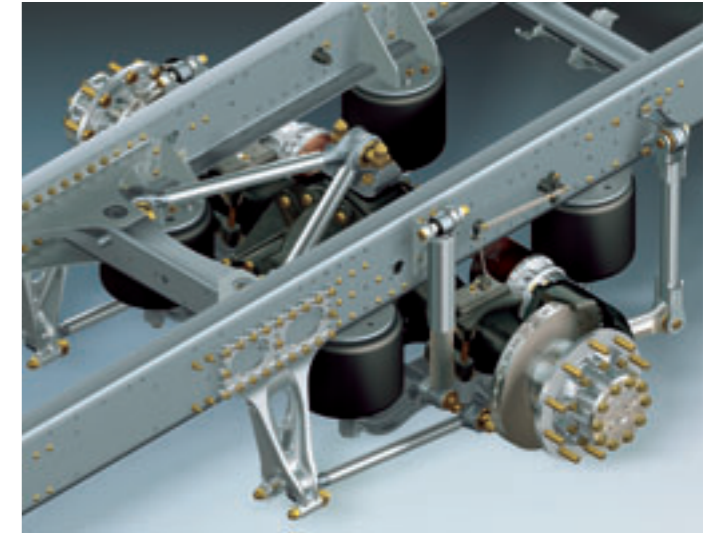

4-bellows rear-axle air suspension for the TGM.
Optional heavy-duty rear axle, load capacity 11.5 tonnes.

Leaf or air springs – the choice is yours.

Standard on the TGL and TGM, the tried-and-tested parabolic-leaf springs with maintenance-free rubber bushings assure a high standard of ride comfort and stability. It's just about the best system of its kind – unless you choose MAN's air suspension, which is similarly maintenance-free and capable of transporting even highly sensitive loads without unnecessary damage. By

means of ECAS (Electronically Controlled Air Suspension), MAN Tronic maintains the vehicle at a constant ride height, regardless of load, but the ride height can easily be varied at a convenient manual control to suit ramps of different heights. For road-going models, the lifting/lowering ranges are 110 mm/70 mm (TGL) and 190 mm/90 mm (TGM).

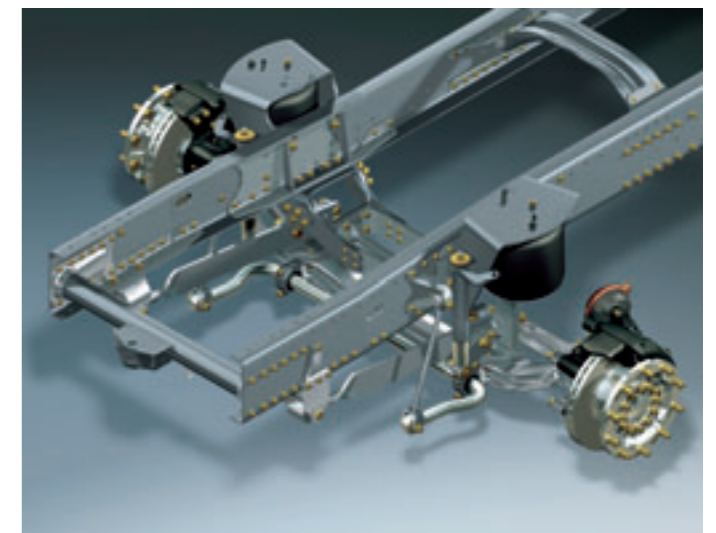

Front-axle air suspension for the TGM.

Two model series, one glance: the TGL/TGM Trucknology® Programme.



TGL

Model	7,49 t	8,0 t	(10,0 t) 12,0 t
Suspension	Leaf/leaf, leaf/air	Leaf/leaf, leaf/air	Leaf/leaf, leaf/air
Drive formula	4x2	4x2	4x2
Tyres	17.5-inch	17.5-inch	17.5-inch
Engine	4-cyl. in-line	4-/6-cyl. in-line	4-/6-cyl. in-line
Power output	110 kW (150 hp) 132 kW (180 hp)	110 kW (150 hp)* 151 kW (206 hp) 176 kW (240 hp)	132 kW (180 hp) 151 kW (206 hp) 176 kW (240 hp)
Transmission	5-/ 6-speed, MAN TipMatic (6-speed)	5-/ 6-/9-speed*, MAN TipMatic (6/12-speed)	6-/ 9-speed, MAN TipMatic (6/12-speed)
Cab	C	C, L, LX, crew cab	C, L, LX, crew cab
Wheelbases	3300 – 5200 mm*	3050 – 5550 mm*	3050 – 6700 mm

*Some additions to the product range will not be available until 2007.

TGM

Model	13,0 t	15,0 t	18,0 t	26,0 t
Suspension	Leaf/air	Leaf/air, full air	Leaf/leaf, leaf/air, full air	Leaf/leaf
Drive formula	4x4	4x2	4x2, 4x4	6x4
Tyres	22.5-inch	19.5-inch	22.5-inch	22.5-inch
Engine	6-cyl. in-line	6-cyl. in-line	6-cyl. in-line	6-cyl. in-line
Power output	176 kW (240 hp) 206 kW (280 hp)	176 kW (240 hp) 206 kW (280 hp)	176 kW (240 hp) 206 kW (280 hp) 240 kW (326 hp)	206 kW (280 hp) 240 kW (326 hp)
Transmission	9-speed, MAN TipMatic (12-speed)	9-speed, MAN TipMatic (12-speed)	9-speed, MAN TipMatic (12-speed)	9-speed, MAN TipMatic (12-speed)
Cab	C, L, crew cab	C, L, LX	C, L, LX, crew cab	C
Wheelbases	3250 – 4250 mm	3525 – 5475 mm	3575 – 6175 mm	3875, 4125

Keep it short: the stopping distance.

Less is more when the brakes go on. To keep stopping distances to a minimum, the Trucknology® family has an electronic brake system (EBS) with Brake Assistant and internally ventilated discs on all wheels. Useful support is provided by the exhaust brake (EVB) that goes into action automatically when you depress the brake pedal. The intelligent MAN BrakeMatic system coordinates the functions of EBS, the exhaust brake and the optional Bremsomat. For instance, it keeps the vehicle at a constant speed when running downhill. To simplify brake disc renewal hub units are a standard feature: wheel bearing assemblies lubricated for life and fitted to the front and rear axles.

Greater safety in view.

So that the driver can see cyclists or pedestrians close to the sides of the truck, the new mirror concept also opens up what used to be known as the blind spot. Every area that could be a potential source of danger as the truck turns a nearside corner is visible. For greater safety at night the headlights throw a broad beam and have clear glass covers, free-form reflectors and H7 halogen bulbs. As an optional extra low-beam headlights using D2R xenon gas-discharge lamps can be specified; they include a headlight cleaning system.



Headlight cleaning system

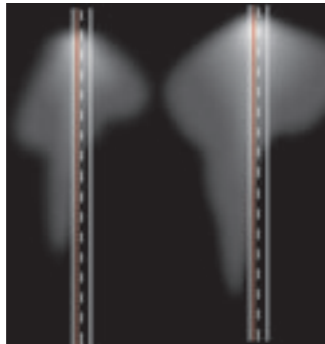

Comparison of road illumination:
Left: H7, right: xenon



Front mirror system

**You can never tell what's coming,
but it's good to be prepared for it.**



Even before a single vehicle had been built the TGL and TGM covered many hundred thousands of kilometres – on our computers. Simulation programs supplied us with essential data for the design of these models. Later, they were tested mercilessly time and again until something very close to perfection was achieved. These trucks are built to cope with the worst conditions encountered anywhere in the world: day-to-day driving.

There are many good reasons why they are so reliable. Quality has been enhanced, for instance, by reducing the total number of parts making them up by 20%. There's another reason too: it's known as MAN Tronic and links all the computer systems, sensors and control units together by CAN bus technology instead of plugs. This reliable, intelligent electronic structure enables wiring lengths and the number of connections to be dramatically reduced. The digital CAN bus system processes large volumes of information in a few thousandths of a second so that control units and regulating devices react almost instantly. MAN Tronic also monitors all the vehicle systems in the network and is used for rapid on- and off-board diagnosis. Operating malfunctions are identified at an early stage before more serious damage can occur.

The electronic systems used on the TGL and TGM reduce off-road and maintenance times, and boost economy in this way too. This useful benefit is enhanced still further by the ProFit Check maintenance system. Servicing information can be called up in good time at the driver information display so that the

maintenance schedules can be planned in advance. Not that servicing is a very frequent event: engine oil change intervals for the TGL and TGM can be as long as 80,000 km on long-distance work. That's yet another example of how MAN trucks help you save time and money.

**"A pity we don't see each other
so often these days."**



You know where you're going. We know how to get you there.

Linking the top technology of the Trucknology® generation with MAN's tailored mobility services gives you a complete range of solutions to transport needs – a well-planned full-service offer from a single source. MAN service packages are configured for the needs of specific trades and business sectors, and for owner-driver or large international logistic companies alike. Each vehicle is not only "ready to run" but is offered with a range of supporting services covering every aspect of planning and operation from choice of body system to road licensing – the 100% Trucknology® service.

MAN mobility services add value to truck operation by maximising economic benefit factors such as flexibility, cost clarity and planning security. Unless you know the facts and figures of your cost management situation and can quantify your total cost of ownership (TCO), you'll find it difficult to succeed in the face of tough competition.

But the choice is still yours: compile a "don't worry" package that suits your specific needs from the individual, internationally available services offered by MAN Finance, MAN Service and MAN Support, which are organised according to a building-block system.

You can rely on mobility made by MAN:

- **Close to hand**
A closely spaced service network with 1,200 outlets throughout Europe
- **Fast**
A 24-hour service in six languages, reached by calling a single number
- **Reliable**
Genuine MAN parts
- **Individual**
Well-planned maintenance and repair or full service contracts, individual financing facilities
- **Problem-free**
No cash needed for payments in Europe
- **Greater efficiency**
Training on the job: MAN training courses for safe and economical driving

MAN Finance	Credit	Financing schemes
	Lease	Leasing schemes
	Rental*	Truck rentals
	CombiContract	Combination of modules from MAN Service and/or MAN Support
MAN Service	Comfort	Maintenance contract (for routine servicing)
	ComfortPlus	Maintenance contract including official testing
	ComfortSuper	Maintenance and repair contract
	ComfortEuro	Maintenance and repair contract valid throughout Europe
	RepairCard/ServiceCard	Non-cash payment facility throughout Europe
	Mobile24	24-hour service throughout Europe
MAN Support	TeleMatics*	Mobile vehicle location and management
	Communication	Mobile communication
	ProfiDrive	Driver training courses
	FleetManagement*	Vehicle and fleet management

* service not fully available in all European countries!

MAN leads the way in many areas. For example environmental protection and quality.



Clean technology.

At our manufacturing plants we pursue a clean-air policy and use water and electricity economically. To avoid squandering valuable resources our vehicles are designed from the start to be suitable for recycling and built to a large extent from materials that can be re-used. All parts that can be recycled are specially marked to identify the material from which they are made. We have greatly increased the proportion of water-soluble paints we use: modern spraying facilities produce far less effluent, recover part of it together with waste heat and trap residual paint. In accordance with ISO 14001 and EMAS standards, we invest a lot of energy in environmental management and introduce improvements wherever possible. All this work is aimed at giving our environment a "clean future".

MAN vehicles are powered by high-tech engines with common-rail fuel injection; they too help to protect the environment by reducing noise and exhaust emissions to a minimum. This

modern engine technology is an ideal basis for compliance with forthcoming European emission limits, and MAN will be providing the necessary technical solutions well in advance of the dates when they will be required by law.

Documented high quality.

"Made by MAN" is acknowledged worldwide to be a guarantee of absolute leading-edge technology. Only one standard is applied to the development and manufacture of our products: the very highest. We have black-and-white proof of this: the quality management systems at all MAN factories have been certified in accordance with the stringent DIN EN ISO 9001 industrial standard. MAN also led the way as the first German vehicle manufacturer to comply with VDA 6.1, the tough German standard that applies to automotive industry suppliers. Our subsidiary companies and all our service outlets in Germany also operate certified quality management systems.

MAN Nutzfahrzeuge Group
Postfach 50 06 20
D-80976 München
www.man-mn.com
A member of the MAN Group

